

## MSM6242B

### DIRECT BUS CONNECTED CMOS REAL TIME CLOCK/CALENDAR

#### DESCRIPTION

The MSM6242B is a silicon gate CMOS Real Time Clock/Calendar for use in direct bus-connection Microprocessor/Microcomputer applications. An on-chip 32.768 KHz crystal oscillator time base is divided to provide addressable 4-bit I/O data for SECONDS, MINUTES, HOURS, DAY OF WEEK, DATE, MONTH and YEAR. Data access is controlled by 4-bit address, chip selects ( $\overline{CS0}$ , CS1),  $\overline{WRITE}$ ,  $\overline{READ}$ , and ALE. Control Registers D, E and F provide for 30 SECOND error adjustment, INTERRUPT REQUEST (IRQ FLAG) and BUSY status bits, clock STOP, HOLD, and RESET FLAG bits, 4 selectable INTERRUPTS rates are available at the STD.P

(STANDARD PULSE) output utilizing Control Register inputs T0, T1 and the ITRPT/STND (INTERRUPT/STANDARD). Masking of the interrupt output (STD.P) can be accomplished via the MASK bit. The MSM6242B can operate in a 12/24 hour format and Leap Year timing is automatic.

The MSM6242B normally operates from a 5V  $\pm 10\%$  supply at  $-40$  to  $85^\circ\text{C}$ . Battery backup operation down to 2.0V allows continuation of time keeping when main power is off. The MSM6242B is offered in a 18-pin plastic DIP and a 24-pin plastic Small Outline package.

#### FEATURES

##### DIRECT MICROPROCESSOR/MICROCONTROLLER BUS CONNECTION

TIME	MONTH	DATE	YEAR	DAY OF WEEK
23:59:59	12	31	80	7

- 4-bit data bus
- 4-bit address bus
- $\overline{READ}$ ,  $\overline{WRITE}$ , ALE and CHIP SELECT INPUTS
- Status registers – IRQ and BUSY
- Selectable interrupt outputs – 1/64 second, 1 second, 1 minute, 1 hour
- Interrupt masking
- 32.768 KHz crystal controlled operation
- 12/24 hour format
- Auto leap year
- $\pm 30$  second error correction
- Single 5V supply
- Battery backup down to  $V_{DD} = 2.0V$
- Low power dissipation:
  - 20 $\mu\text{W}$  max at  $V_{DD} = 2V$
  - 150 $\mu\text{W}$  max at  $V_{DD} = 5V$
- 18 pin Plastic DIP (DIP18-P-300)
- 24 Pin-V Plastic SOP (SOP24-P-430-VK)

FUNCTIONAL BLOCK DIAGRAM

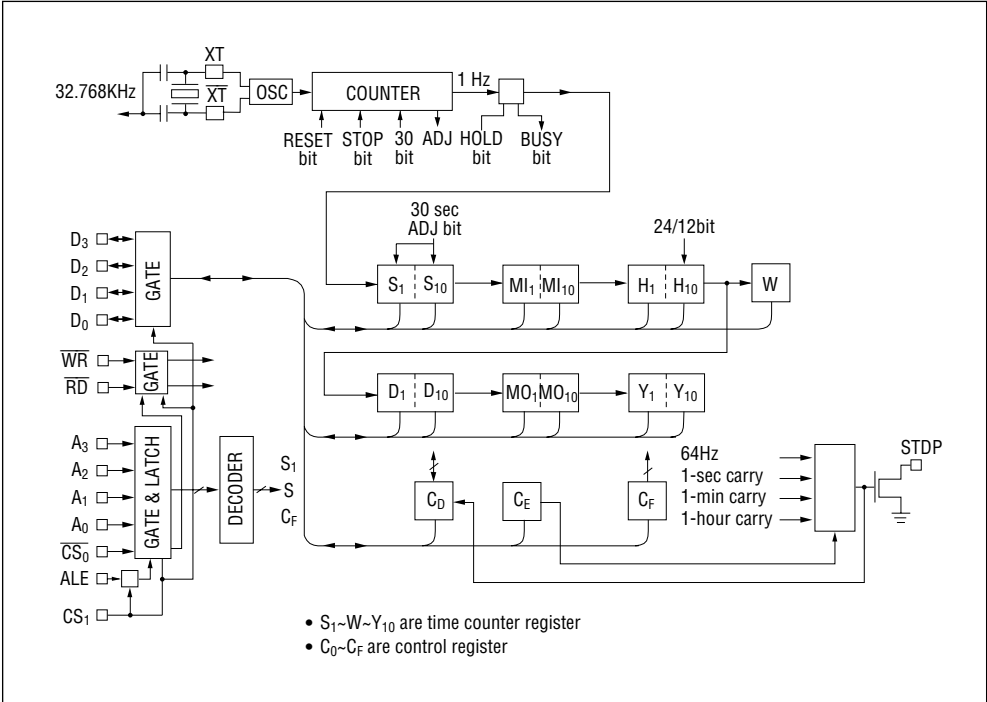

PIN CONFIGURATION

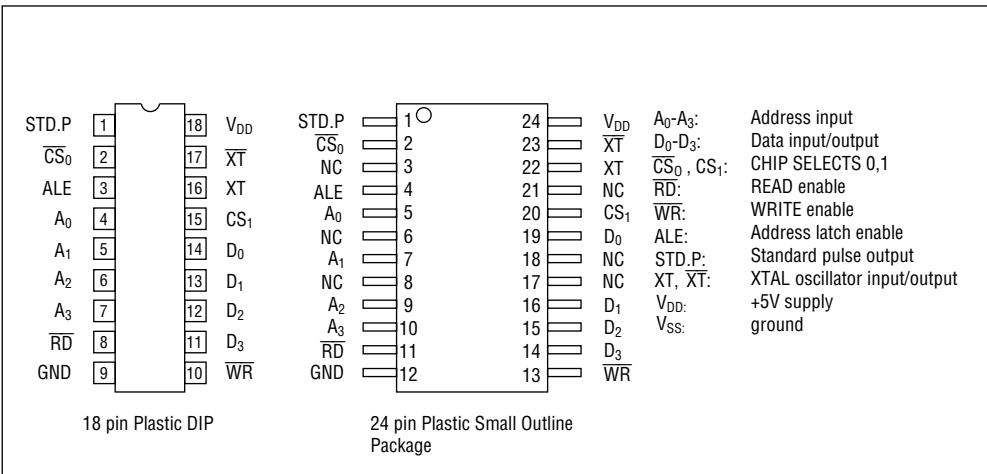

REGISTER TABLE

Address Input	Address Input				Register Name	Data				Count value	Description
	A <sub>3</sub>	A <sub>2</sub>	A <sub>1</sub>	A <sub>0</sub>		D <sub>3</sub>	D <sub>2</sub>	D <sub>1</sub>	D <sub>0</sub>		
0	0	0	0	0	S <sub>1</sub>	S <sub>8</sub>	S <sub>4</sub>	S <sub>2</sub>	S <sub>1</sub>	0 to 9	1-second digit register
1	0	0	0	1	S <sub>10</sub>	*	S <sub>40</sub>	S <sub>20</sub>	S <sub>10</sub>	0 to 5	10-second digit register
2	0	0	1	0	M <sub>1</sub>	mi <sub>8</sub>	mi <sub>4</sub>	mi <sub>2</sub>	mi <sub>1</sub>	0 to 9	1-minute digit register
3	0	0	1	1	M <sub>10</sub>	*	mi <sub>40</sub>	mi <sub>20</sub>	mi <sub>10</sub>	0 to 5	10-minute digit register
4	0	1	0	0	H <sub>1</sub>	h <sub>8</sub>	h <sub>4</sub>	h <sub>2</sub>	h <sub>1</sub>	0 to 9	1-hour digit register
5	0	1	0	1	H <sub>10</sub>	*	PM/AM	h <sub>20</sub>	h <sub>10</sub>	0 to 2 or 0 to 1	PM/AM, 10-hour digit register
6	0	1	1	0	D <sub>1</sub>	d <sub>8</sub>	d <sub>4</sub>	d <sub>2</sub>	d <sub>1</sub>	0 to 9	1-day digit register
7	0	1	1	1	D <sub>10</sub>	*	*	d <sub>20</sub>	d <sub>10</sub>	0 to 3	10-day digit register
8	1	0	0	0	MO <sub>1</sub>	mo <sub>8</sub>	mo <sub>4</sub>	mo <sub>2</sub>	mo <sub>1</sub>	0 to 9	1-month digit register
9	1	0	0	1	MO <sub>10</sub>	*	*	*	MO <sub>10</sub>	0 to 1	10-month digit register
A	1	0	1	0	Y <sub>1</sub>	y <sub>8</sub>	y <sub>4</sub>	y <sub>2</sub>	y <sub>1</sub>	0 to 9	1-year digit register
B	1	0	1	1	Y <sub>10</sub>	y <sub>80</sub>	y <sub>40</sub>	y <sub>20</sub>	y <sub>10</sub>	0 to 9	10-year digit register
C	1	1	0	0	W	*	w <sub>4</sub>	w <sub>2</sub>	w <sub>1</sub>	0 to 6	Week register
D	1	1	0	1	C <sub>D</sub>	30 sec. ADJ	IRQ FLAG	BUSY	HOLD	—	Control Register D
E	1	1	1	0	C <sub>E</sub>	t <sub>1</sub>	t <sub>0</sub>	ITRPT /STND	MASK	—	Control Register E
F	1	1	1	1	C <sub>F</sub>	TEST	24/12	STOP	REST	—	Control Register F

REST = RESET

ITRPT/STND = INTERRUPT/STANDARD

**Note 1)** — Bit \* does not exist (unrecognized during a write and held at "0" during a read).

**Note 2)** — Be sure to mask the AM/PM bit when processing 10's of hour's data.

**Note 3)** — BUSY bit is read only. The IRQ FLAG bit can only be set to a "0". Setting the IRQ FLAG to a "1" is done by hardware.

**Note 4)** — PM at 1 and AM at 0 for PM / AM bit.

Figure 1. Register Table

OSCILLATOR FREQUENCY DEVIATIONS

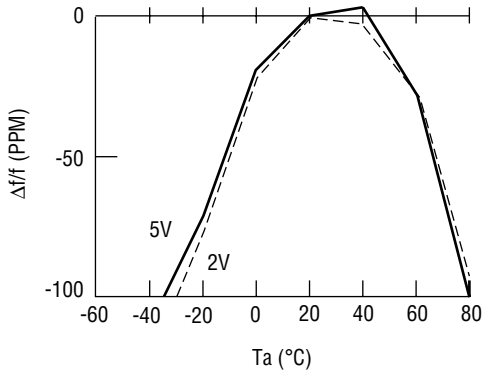

Figure 2. Frequency Deviation (PPM) vs Temperature

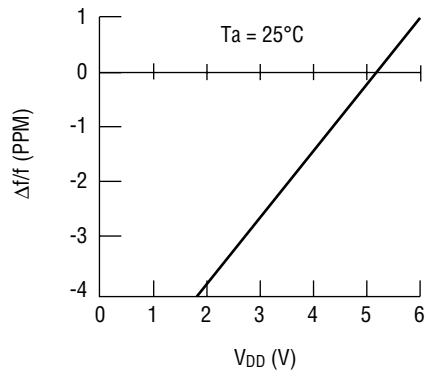
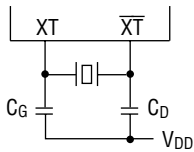

Figure 3. Frequency Deviation (PPM) vs Voltage

**Note:** 1. The graphs above showing frequency deviation vs temperature/voltage are primarily characteristic of the MSM6242B with the oscillation circuit described below.



Crystal: Type N<sub>0</sub>, P<sub>3</sub> by kinseki (32.768 KHz)  
 C<sub>G</sub>, C<sub>D</sub>: 22pF (Temperature Characteristics: 0)

### ABSOLUTE MAXIMUM RATINGS

Parameter	Symbol	Condition	Rating	Unit
Power Supply Voltage	$V_{DD}$	$T_a = 25^\circ\text{C}$	-0.3 to 7	V
Input Voltage	$V_I$		-0.3 to $V_{DD} + 0.3$	V
Output Voltage	$V_O$		-0.3 to $V_{DD} + 0.3$	V
Storage Temperature	$T_{STG}$		-55 to +150	$^\circ\text{C}$

### OPERATING CONDITIONS

Parameter	Symbol	Condition	Rating	Unit
Power Supply Voltage	$V_{DD}$	—	4 to 6	V
Standby Supply Voltage	$V_{BAK}$	—	2 to 6	
Crystal Frequency	$f_{(XT)}$	—	32.768	kHz
Operating Temperature	$T_{OP}$	—	-40 to +85	$^\circ\text{C}$

### D.C. Characteristics

( $V_{DD} = 5V \pm 10\%$ ,  $T_A = -40 \sim +85$ )

Parameter	Symbol	Condition	Min.	Typ.	Max.	Unit	Applicable Terminal	
"H" Input Voltage	$V_{IH1}$	—	2.2	—	—	V	All input terminals except CS <sub>1</sub> , XT	
"L" Input Voltage	$V_{IL1}$	—	—	—	0.8			
Input Leak Current	$I_{LK1}$	$V_I = V_{DD}/0V$	—	—	1/-1	$\mu\text{A}$	Input terminals other than D <sub>0</sub> ~ D <sub>3</sub> , XT	
Input Leak Current	$I_{LK2}$		—	—	10/-10		D <sub>0</sub> ~ D <sub>3</sub>	
"L" Output Voltage	$V_{OL1}$	$I_{OL} = 2.5\text{mA}$	—	—	0.4	V	D <sub>0</sub> ~ D <sub>3</sub>	
"H" Output Voltage	$V_{OH}$	$I_{OH} = -400\mu\text{A}$	2.4	—	—			
"L" Output Voltage	$V_{OL2}$	$I_{OL} = 2.5\text{mA}$	—	—	0.4	V	STD.P	
OFF Leak Current	$I_{OFFLK}$	$V = V_{DD}/0V$	—	—	10	$\mu\text{A}$		
Input Capacitance	$C_I$	Input frequency 1MHz	—	5	—	PF	All input terminals	
Current Consumption	$I_{DD1}$	$f_{(xt)} = 32.768\text{ KHz}$ $CS_1 \approx 0$	$V_{DD} = 5V$	—	—	30	$\mu\text{A}$	$V_{DD}$
Current Consumption	$I_{DD2}$			$V_{DD} = 2V$	—	—		
"H" Input Voltage	$V_{IH2}$	$V_{DD} = 2 \sim 5.5V$	$4/5V_{DD}$	—	—	V	CS <sub>1</sub>	
"L" Input Voltage	$V_{IL2}$		—	—	$1/5V_{DD}$			

**SWITCHING CHARACTERISTICS**

**(1) WRITE mode (ALE = V<sub>DD</sub>)**

(V<sub>DD</sub> = 5V ± 10% Ta = -40 to +85°C)

Parameter	Symbol	Condition	Min.	Max.	Unit
CS <sub>1</sub> Set up Time	t <sub>C1S</sub>	—	1000	—	ns
CS <sub>1</sub> Hold Time	t <sub>C1H</sub>	—	1000	—	
Address Stable Before WRITE	t <sub>AW</sub>	—	20	—	
Address Stable After WRITE	t <sub>WA</sub>	—	10	—	
WRITE Pulse Width	t <sub>WW</sub>	—	120	—	
Data Set up Time	t <sub>DS</sub>	—	100	—	
Data Hold Time	t <sub>DH</sub>	—	10	—	
$\overline{RD}$ / $\overline{WR}$ Recovery Time	t <sub>RCV</sub>	—	60	—	

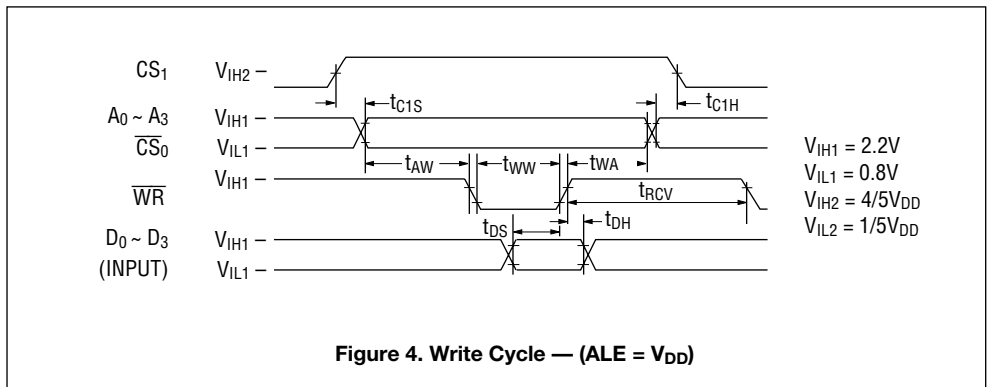

**(2) WRITE mode (With use of ALE)**

(V<sub>DD</sub> = 5V ± 10%, Ta = -40 ~ +85°C)

Parameter	Symbol	Condition	Min.	Max.	Unit
CS <sub>1</sub> Set up Time	t <sub>C1S</sub>	—	1000	—	ns
Address Set up Time	t <sub>AS</sub>	—	25	—	
Address Hold Time	t <sub>AH</sub>	—	25	—	
ALE Pulse Width	t <sub>AW</sub>	—	40	—	
ALE Before WRITE	t <sub>ALW</sub>	—	10	—	
WRITE Pulse Width	t <sub>WW</sub>	—	120	—	
ALE After WRITE	t <sub>WAL</sub>	—	20	—	
DATA Set up Time	t <sub>DS</sub>	—	100	—	
DATA Hold Time	t <sub>DH</sub>	—	10	—	
CS <sub>1</sub> Hold Time	t <sub>C1H</sub>	—	1000	—	
$\overline{RD}$ / $\overline{WR}$ Recovery Time	t <sub>RCV</sub>	—	60	—	

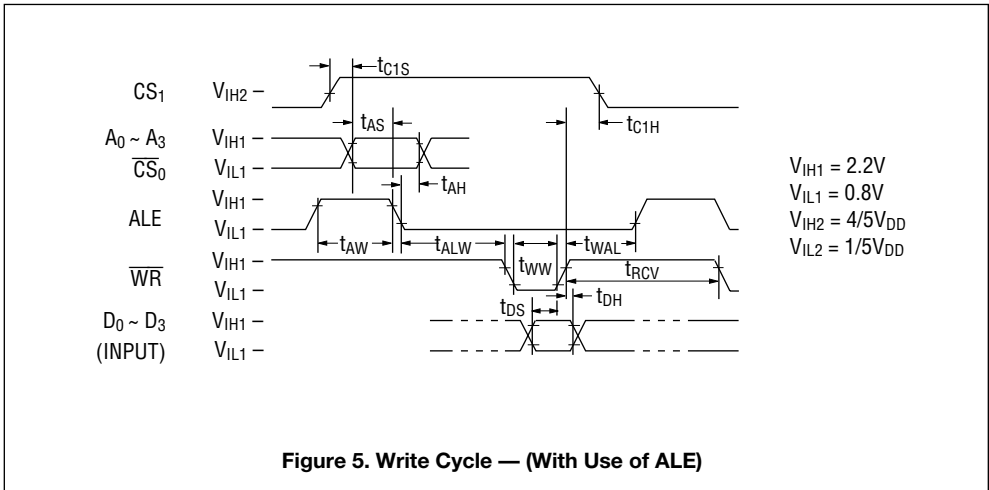

**(3) READ mode (ALE = V<sub>DD</sub>)**

(V<sub>DD</sub> = 5V ± 10%, Ta = -40 to +85°C)

Parameter	Symbol	Condition	Min.	Max.	Unit
CS <sub>1</sub> Set up Time	t <sub>C1S</sub>	—	1000	—	ns
CS <sub>1</sub> Hold Time	t <sub>C1H</sub>	—	1000	—	
Address Stable before READ	t <sub>AR</sub>	—	20	—	
Address Stable after READ	t <sub>RA</sub>	—	0	—	
$\overline{RD}$ to Data	t <sub>RD</sub>	C <sub>L</sub> = 150pF	—	120	
Data Hold	t <sub>DR</sub>	—	0	—	
$\overline{RD}$ / $\overline{WR}$ Recovery Time	t <sub>RCV</sub>	—	60	—	

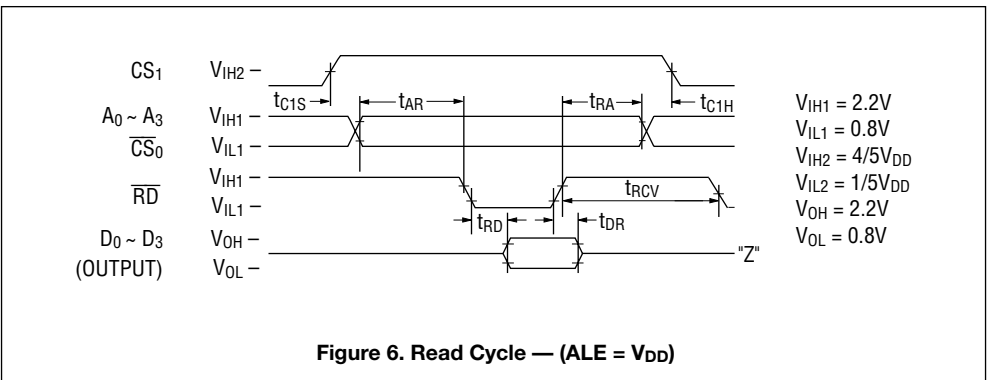

(4) READ mode (With use of ALE)

( $V_{DD} = 5V \pm 10\%$ ,  $T_a = -40$  to  $+85^\circ\text{C}$ )

Parameter	Symbol	Condition	Min.	Max.	Unit
CS <sub>1</sub> Set up Time	$t_{C1S}$	—	1000	—	ns
Address Set up Time	$t_{AS}$	—	25	—	
Address Hold Time	$t_{AH}$	—	25	—	
ALE Pulse Width	$t_{AW}$	—	40	—	
ALE before READ	$t_{ALR}$	—	10	—	
ALE after READ	$t_{RAL}$	—	10	—	
RD to Data	$t_{RD}$	$C_L = 150\text{pF}$	—	120	
DATA Hold	$t_{DR}$	—	0	—	
CS <sub>1</sub> Hold Time	$t_{C1H}$	—	1000	—	
$\overline{\text{RD}} / \overline{\text{WR}}$ Recovery Time	$t_{RCV}$	—	60	—	

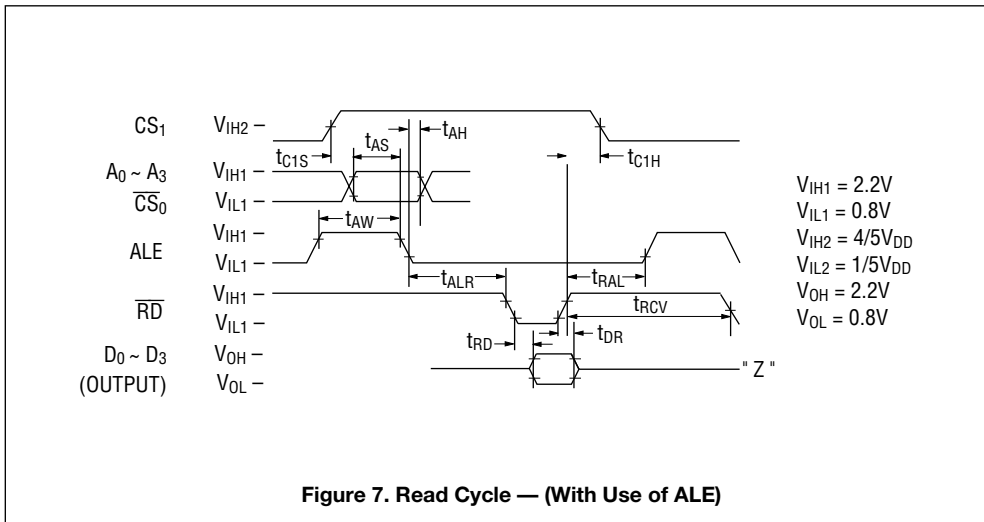



**PIN DESCRIPTION**

Name	Pin No.		Description
	RS	GS	
D <sub>0</sub>	14	19	Data Input/Output pins to be directly connected to a microcontroller bus for reading and writing of the clock/calendar's registers and control registers. D <sub>0</sub> = LSB and D <sub>3</sub> = MSB.
D <sub>1</sub>	13	16	
D <sub>2</sub>	12	15	
D <sub>3</sub>	11	14	
A <sub>0</sub>	4	5	Address input pin for use by a microcomputer to select internal clock/calendar's registers and control registers for Read/Write operations (See Function Table Figure 1). Address input pins A <sub>0</sub> -A <sub>3</sub> are used in combination with ALE for addressing registers.
A <sub>1</sub>	5	7	
A <sub>2</sub>	6	9	
A <sub>3</sub>	7	10	
ALE	3	4	Address Latch Enable pin. This pin enables writing of address data when ALE = 1 and $\overline{CS_0} = 0$ ; address data is latched when ALE = 0. Microcontroller/Microprocessors having an ALE output should connect to this pin; otherwise it should be connected at V <sub>DD</sub> .
$\overline{WR}$	10	13	Writing of data is performed by this pin. When CS <sub>1</sub> = 1 and $\overline{CS_0} = 0$ , D <sub>0</sub> ~ D <sub>3</sub> data is written into the register at the rising edge of $\overline{WR}$ .
$\overline{RD}$	8	11	Reading of register data is accomplished using this pin. When CS <sub>1</sub> = 1, $\overline{CS_0} = 0$ and $\overline{RD} = 0$ , the data of this register is output to D <sub>0</sub> ~ D <sub>3</sub> . If both $\overline{RD}$ and $\overline{WR}$ are set at 0 simultaneously, $\overline{RD}$ is to be inhibited.
$\overline{CS_0}$	2	2	Chip Select pins. These pins enable/disable ALE, $\overline{RD}$ and $\overline{WR}$ operation. $\overline{CS_0}$ and ALE work in combination with one another, while CS <sub>1</sub> work independent with ALE. CS <sub>1</sub> must be connected to power failure detection as shown in Figure 18.
CS <sub>1</sub>	15	20	
STD.P	1	1	Output pin of N-CH OPEN DRAIN type. The output data is controlled by the D <sub>1</sub> data content of C <sub>E</sub> register. This pin has a priority to $\overline{CS_0}$ and CS <sub>1</sub> . Refer to Figure 9 and FUNCTIONAL DESCRIPTION OF REGISTERS.
XT	16	22	32.768 kHz crystal is to be connected to these pins. When an external clock of 32.768 kHz is to be used for MSM6242's oscillation source, either CMOS output or pull-up TTL output is to be input from XT, while $\overline{XT}$ should be left open.
$\overline{XT}$	17	23	
V <sub>DD</sub>	18	24	Power supply pin. +2 ~ +6V power is to be applied to this pin.
GND	9	12	Ground pin.

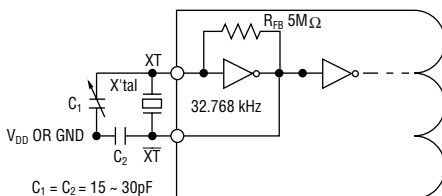

The impedance of the crystal should be less than 30kΩ

**Figure 8. Oscillator Circuit**

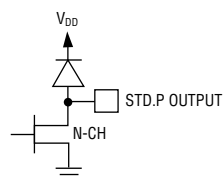

**Figure 9.**

**FUNCTIONAL DESCRIPTION OF REGISTERS**

**S<sub>1</sub>, S<sub>10</sub>, MI<sub>1</sub>, MI<sub>10</sub>, H<sub>1</sub>, H<sub>10</sub>, D<sub>1</sub>, D<sub>10</sub>, MO<sub>1</sub>, MO<sub>10</sub>, Y<sub>1</sub>, Y<sub>10</sub>, W**

- a) These are abbreviations for SECOND1, SECOND10, MINUTE1, MINUTE10, HOUR1, HOUR10, DAY1, DAY10, MONTH1, MONTH10, YEAR1, YEAR10, and WEEK. These values are in BCD notation.
- b) All registers are logically positive. For example, (S8, S4, S2, S1) = 1001 which means 9 seconds.
- c) If data is written which is out of the clock register data limits, it can result in erroneous clock data being read back.
- d) PM/AM, h<sub>20</sub>, h<sub>10</sub>  
 In the mode setting of 24-hour mode, PM/AM bit is ignored, while in the setting of 12-hour mode h<sub>20</sub> is to be set. Otherwise it causes a discrepancy. In reading out the PM/AM bit in the 24-hour mode, it is continuously read out as 0. In reading out h<sub>20</sub> bit in the 12-hour mode, 0 is written into this bit first, then it is continuously read out as 0 unless 1 is being written into this bit.
- e) Registers Y1, Y10, and Leap Year. The MSM6242B is designed exclusively for the Christian Era and is capable of identifying a leap year automatically. The result of the setting of a non-existent day of the month is shown in the following example: If the date February 29 or November 31, 1985, was written, it would be changed automatically to March 1, or December 1, 1985 at the exact time at which a carry pulse occurs for the day's digit.
- f) The Register W data limits are 0 – 6 (Tabel 1 shows a possible data definition).

**TABLE 1**

W <sub>4</sub>	W <sub>2</sub>	W <sub>1</sub>	Day of Week
0	0	0	Sunday
0	0	1	Monday
0	1	0	Tuesday
0	1	1	Wednesday
1	0	0	Thursday
1	0	1	Friday
1	1	0	Saturday

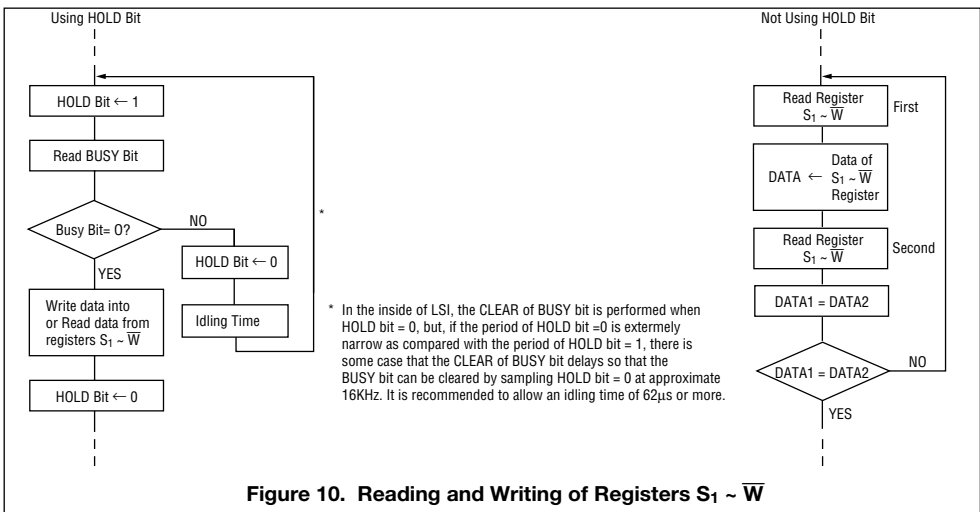

**Figure 10. Reading and Writing of Registers S<sub>1</sub> ~ W**

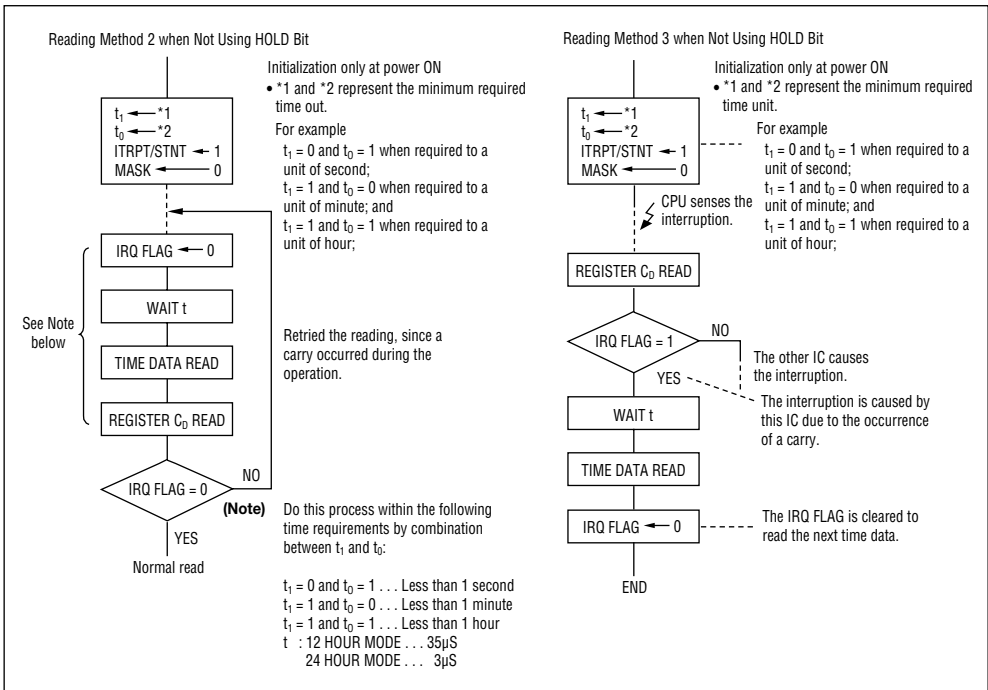

**CD REGISTER (Control D Register)**

- a) HOLD (D0) – Setting this bit to a "1" inhibits the 1Hz clock to the S1 counter, at which time the Busy status bit can be read. When Busy = 0, register's  $S_1 \sim \bar{W}$  can be read or written. During this procedure if a carry occurs the S1 counter will be incremented by 1 second after HOLD = 0 (this condition is guaranteed as long as HOLD = 1 does not exceed 1 second in duration). If CS1 = 0 then HOLD = 0 irrespective of any condition.
- b) BUSY (D1) – Status bit which shows the interface condition with microcontroller/microprocessors. As for the method of writing into and reading from  $S_1 \sim \bar{W}$  (address  $\phi \sim C$ ), refer to the flow chart described in Figure 10.
- c) IRQ FLAG (D2) – This status bit corresponds to the output level of the STD.P output. When STD.P = 0, then IRQ = 1; when STD.P = 1, then IRQ = 0. The IRQ FLAG indicates that an interrupt has occurred to the microcomputer if IRQ = 1. When D0 of register  $C_E$  (MASK) = 0, then the STD.P output changes according to the timing set by D3 ( $t_1$ ) and D2 ( $t_0$ ) of register E. When D1 of register E (ITRPT/STND) = 1 (interrupt mode), the STD.P output remains low until the IRQ FLAG is written to a "0". When IRQ = 1 and timing for a new interrupt occurs, the new interrupt is ignored. When ITRPT/STND = 0 (Standard Pulse Output mode) the STD.P output remains low until either "0" is written to the IRQ FLAG; otherwise, the IRQ FLAG automatically goes to "0" after 7.8125ms. When writing the HOLD or 30 second adjust bits of register D, it is necessary to write the IRQ FLAG bit to a "1".
- d)  $\pm 30$  ADJ (D3) – When 30-second adjustment is necessary, a "1" is written to bit D3 during which time the internal clock registers should not be read from or written to 125 $\mu$ s after bit D3 = 1 it will automatically return to a "0", and at that time reading or writing of registers can occur.

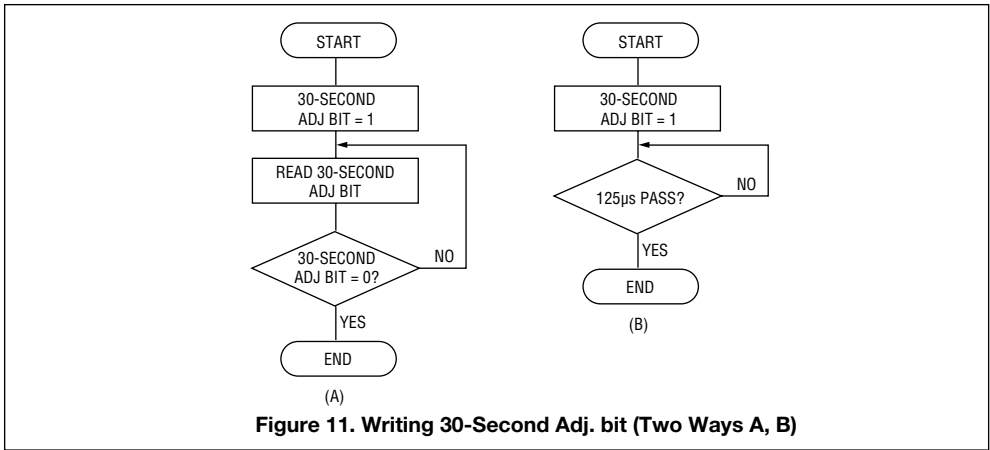

Figure 11. Writing 30-Second Adj. bit (Two Ways A, B)

**CE REGISTER (Control E Register)**

- a) MASK (D0) – This bit controls the STD.P output. When MASK = 1, then STD.P = 1 (open); when MASK = 0, then STD.P = output mode. The relationship between the MASK bit and STD.P output is shown Figure 12.
- b) ITRPT/STND (D1) – The ITRPT/STND input is used to switch the STD.P output between its two modes of operation, interrupt and Standard timing waveforms. When ITRPT/STND = 0 a fixed cycle waveform with a low-level pulse width of 7.8125ms is present at the STD.P output. At this time the MASK bit must equal 0, while the period in either mode is determined by T0 (D2) and T1 (D3) of Register E.
- c) T0 (D2), T1 (D3) – These two bits determine the period of the STD.P output in both interrupt and Fixed timing waveform modes. The tables below show the timing associated with the T0, T1 inputs as well as their relationship to INTRPT/STND and STD.P.

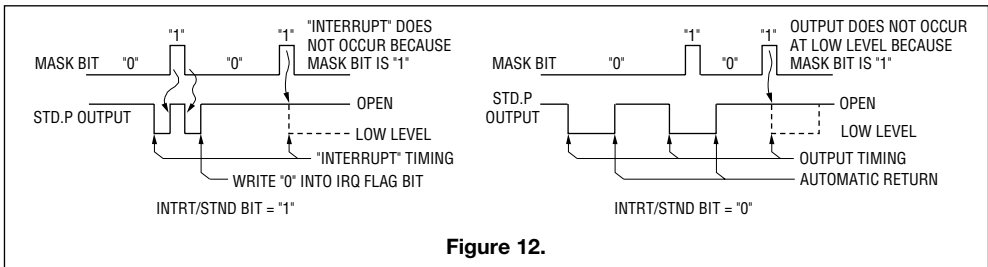
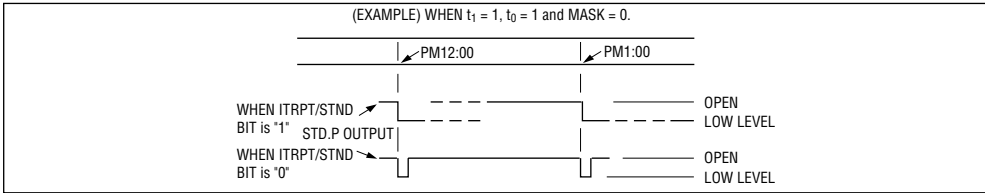

Figure 12.

**TABLE 2**

t <sub>1</sub>	t <sub>0</sub>	Period	Duty CYCLE of "0" level when ITRPT/STND bit is "0".
0	0	1/64 second	1/2
0	1	1 second	1/128
1	0	1 minute	1/7680
1	1	1 hour	1/460800

The timing of the STD.P output designated by T1 and T0 occurs the moment that a carry occurs to a clock digit.



- d) The low-level pulse width of the fixed cycle waveform (ITRPT/STND = 0) is 7.8125ms independent of T0/T1 inputs.
- e) The fixed cycle waveform mode can be used for adjustment of the oscillator frequency time base. (See Figure 14).
- f) During  $\pm 30$  second adjustment a carry can occur that will cause the STD.P output to go low when T0/T1 = 1,0 or 1,1. However, when T1/T0 = 0, 0 and ITRPT/STND = 0, carry does not occur and the STD.P output resumes normal operation.
- g) The STD.P output is held (frozen) at the point at which STOP = 1 while ITRPT/STND = 0.
- h) No STD.P output change occurs as a result of writing data to registers S1 ~ H1.

**C<sub>F</sub> REGISTER (Control F Register)**

- a) REST (D0) – This bit is used to clear the clock's internal divider/counter of less than a second. When REST = 1, the counter is Reset for the duration of REST. In order to release this counter from Reset, a "0" must be written to the REST bit. If CSI = 0 then REST = 0 automatically.
- b) STOP (D1) – The STOP FLAG Only inhibits carries into the 8192Hz divider stage. There may be up to 122 $\mu$ s delay before timing starts or stops after changing this flag; 1 = STOP/0 = RUN.

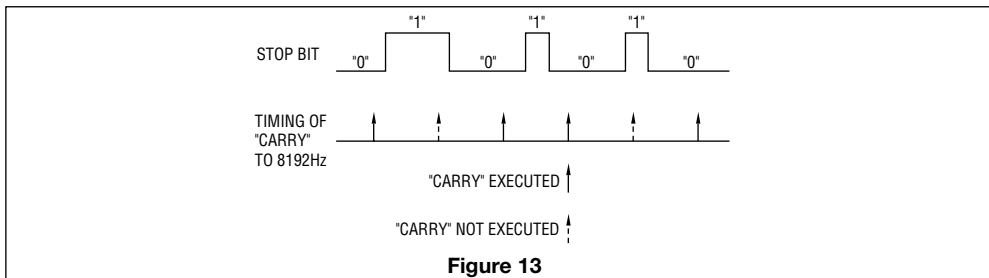

**Figure 13**

- c) 24/12 (D2) – This bit is for selection of 24/12 hour time modes. If D2 = 1–24 hour mode is selected and the PM/AM bit is invalid. If D2 = 0–12 hour mode is selected and the PM/AM bit is valid.  
 "24/HOUR/  
12 HOUR"  
 Setting of the 24/12 hour bit is as follows:  
 1) REST bit = 1  
 2) 24/12 hour bit = 0 or 1  
 3) REST bit = 0  
 \* REST bit must = 1 to write to the 24/12 hour bit.
- d) TEST (D3) – When the TEST flag is a "1", the input to the SECONDS counter comes from the counter/divider stage instead of the 15th divider stage. This makes the SECONDS counter count at 5.4163KHz instead of 1Hz. When TEST = 1 (Test Mode) the STOP & REST (Reset) flags do not inhibit internal counting. When Hold = 1 during Test (Test = 1) internal counting is inhibited; however, when the HOLD FLAG goes inactive (Hold = 0) counter updating is not guaranteed.

**TYPICAL APPLICATION INTERFACE WITH MSM6242B AND MICROCONTROLLERS**

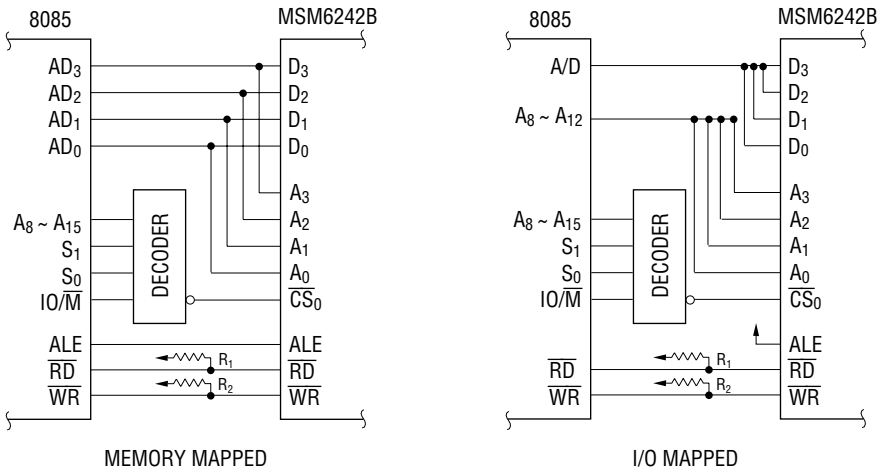

Note : If 8085 does not enter into the state of HALT or HOLD during CS<sub>1</sub> = "H" of MSM6242B, R<sub>1</sub> and R<sub>2</sub> are not required.

**Figure 15.**

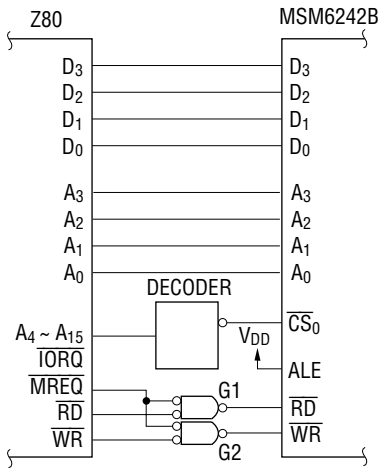

Note : It depends upon the switching characteristics decided by a X'tal used for a Z80 that either of IOREQ and MREQ is used.

**Figure 16.**

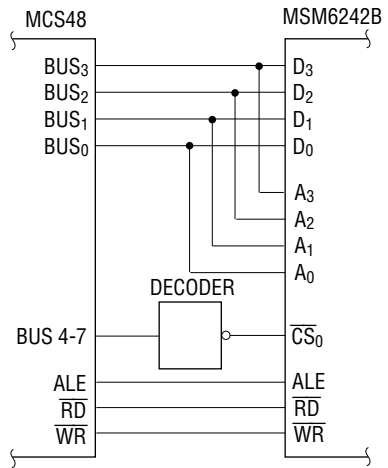

**Figure 17.**

TYPICAL APPLICATIONS — INTERFACE WITH MSM80C49

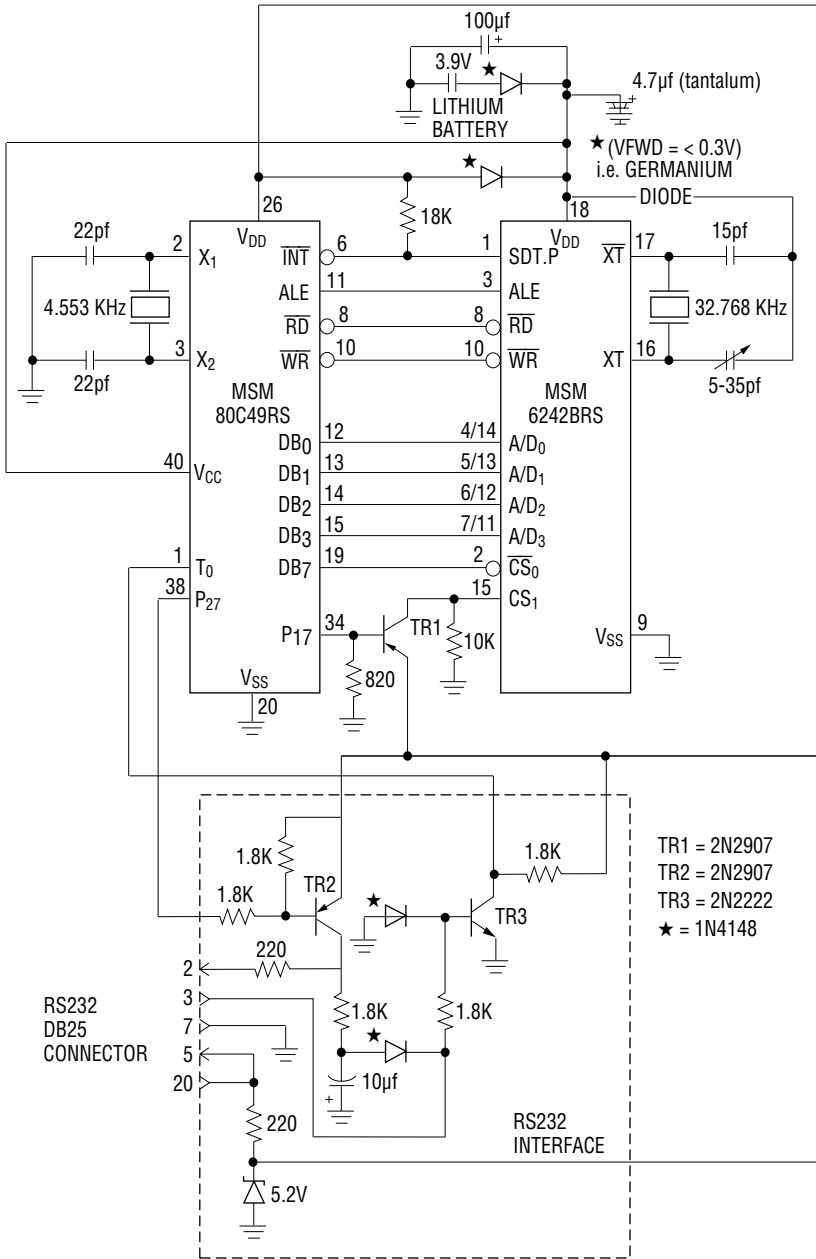
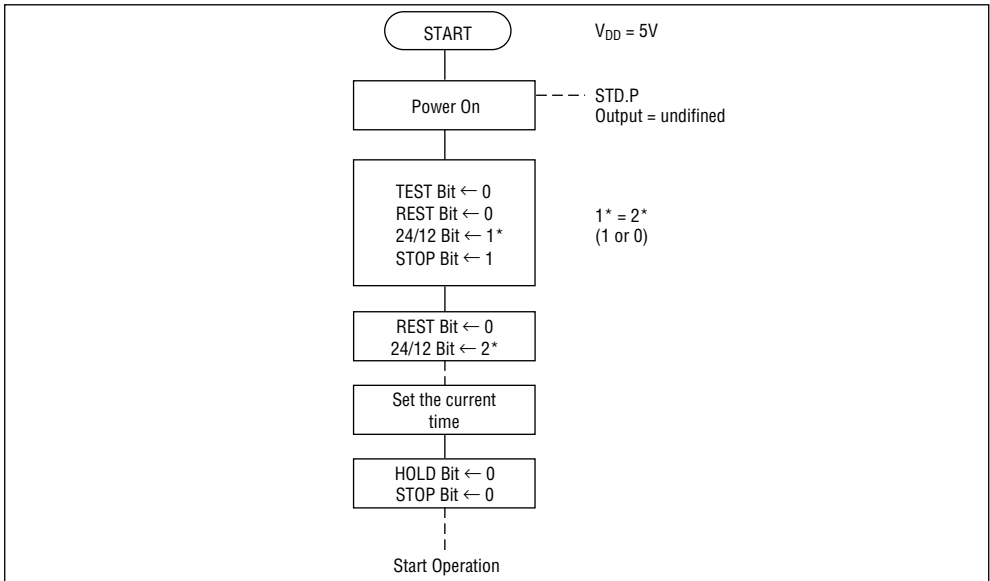

Figure 18.

APPLICATION NOTE

1. Power Supply



2. Adjustment of Frequency

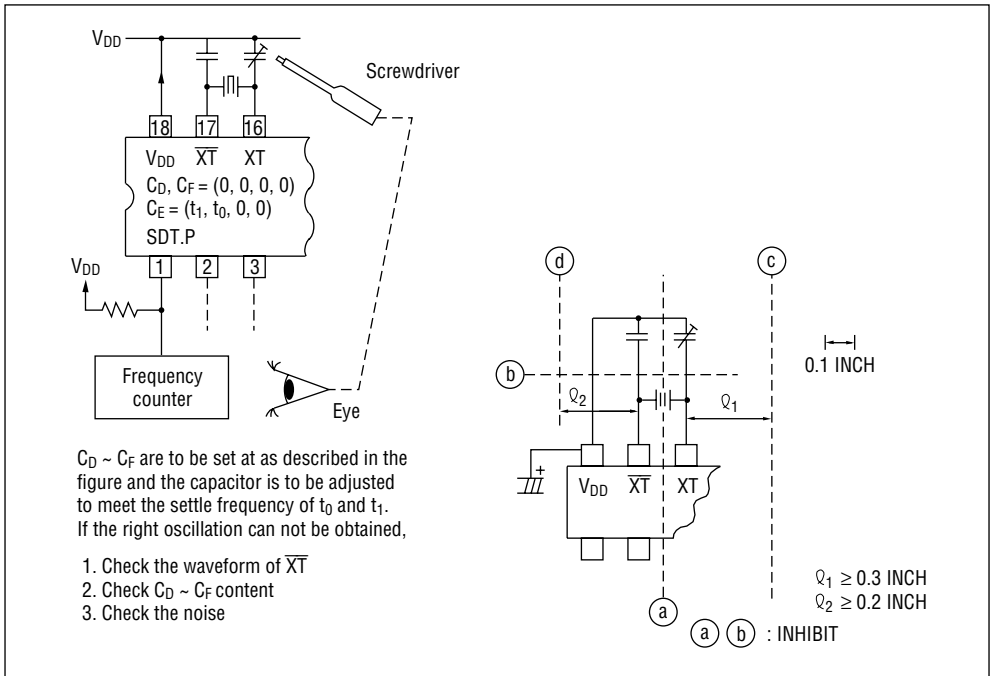



### 3. CH<sub>1</sub> (Chip Select)

V<sub>IH</sub> and V<sub>IL</sub> of CH<sub>1</sub> has 3 functions.

- a) To accomplish the interface with a microcontroller/microprocessor.
- b) To inhibit the control bus, data bus and address bus and to reduce input gate pass current in the stand-by mode.
- c) To protect internal data when the mode is moved to and from standby mode.

To realize the above functions:

- a) More than  $4/5 V_{DD}$  should be applied to the MSM6242B for the interface with a microcontroller/microprocessor in 5V operation.
- b) In moving to the standby mode,  $1/5 V_{DD}$  should be applied so that all data buses should be disabled. In the standby mode, approx. 0V should be applied.
- c) To and from the standby mode, obey following Timing chart.

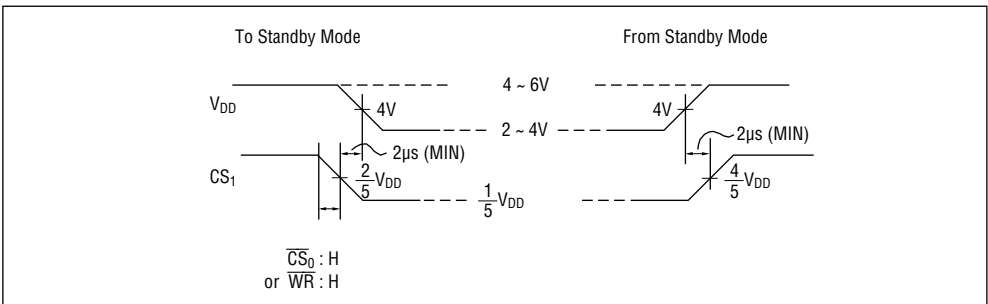

### 4. Set SDT.P at alarm mode

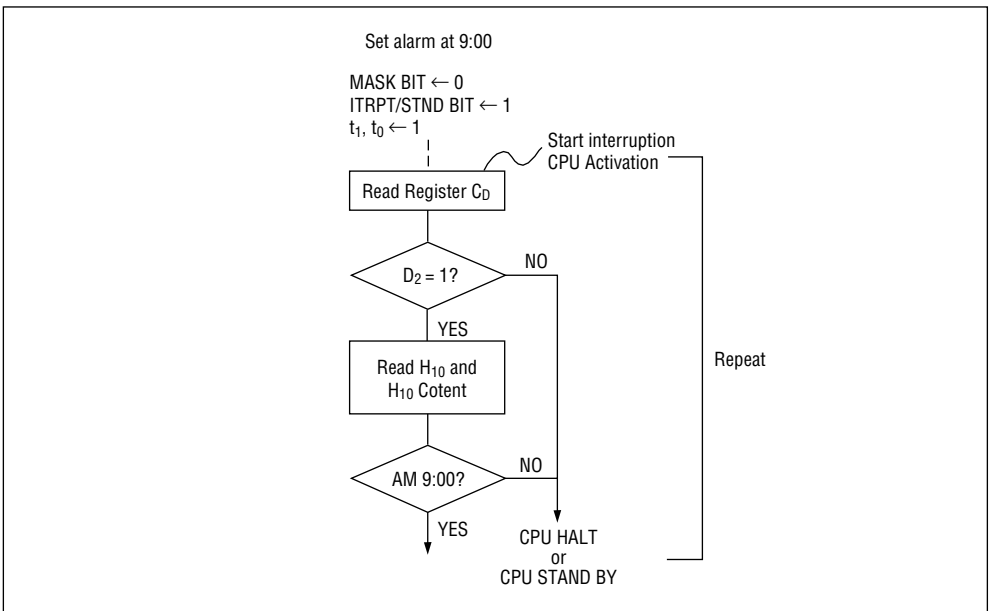

TYPICAL APPLICATION — POWER SUPPLY CIRCUIT

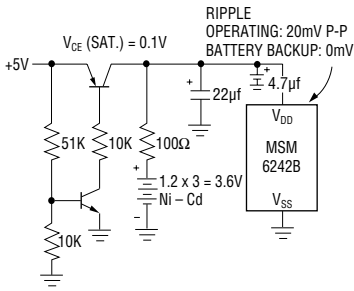

Figure 19.

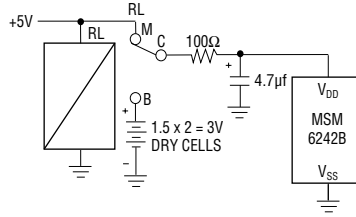

Figure 20.

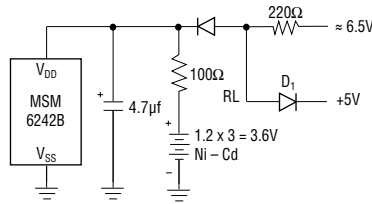

Figure 21.

4.7μF: tantalum

SUPPLEMENTARY DESCRIPTION

- When "0" is written to the IRQ FLAG bit, the IRQ FLAG bit is cleared. However, if "0" is assigned to the IRQ FLAG bit when written to the other bits, the 30-sec ADJ bit and the HOLD bit, the IRQ FLAG = 1 and was generated before the writing and IRQ FLG = 1 generated in a moment then will be cleared. To avoid this, always set "1" to the IRQ FLAG unless "0" is written to it intentionally. By writing "1" to it, the IRQ FLAG bit does not become "1".
- Since the IRQ FLAG bit becomes "1" in some cases when rewriting either of the  $t_1$ ,  $t_0$ , or ITRPT/STND bit of register  $C_E$ , be sure to write "0" to the IRQ FLAG bit after writing to make valid the IRQ FLAG = 1 to be generated after it.
- \* The relationship between STD.P OUT and IRQ FLAG bit is shown below:

